

TE-6700

# 2nd Generation Temperature Elements

## Description

The TE-6700 Series is our 2nd Generation of temperature elements. These attractively styled, feature-packed temperature sensing products offer ease of installation, user friendliness, and application flexibility in one package.

The TE-6700 Series Temperature Elements supersede the TE-6400 Series for space sensing applications. The 2nd Generation elements are designed for use with most Johnson Controls controllers, and now work directly with the VMA1200 and VMA1400 Series controllers.

**IMPORTANT:** The Printed Circuit Board (PCB) is retained with a tamper-resistant mechanism. Removal of the PCB from the plastic housing will void the product warranty.

## Features

- temperature sensor Time Response Improvement (TRI) provides better temperature local control, increases employee comfort, and reduces energy consumption
- controller configuration switch allows users to choose occupancy features that match the application and controller
- occupancy Light-Emitting Diode (LED) indicator displays the controller's current operating mode
- manual override pushbutton (PB) signals the controller that the space is occupied; this overrides time-of-day scheduling
- globally scaled units include setpoint and bulb indicator (both optional) that measure Fahrenheit and Celsius ranges, 65 to 85°F (19 to 29°C)
- universal mounting — ships with wallbox and surface mounting plate (all installation hardware included)



TE-6700 Series Temperature Elements

- single or dual setpoint adjustment allows for separate heating and cooling settings; this makes setpoint viewing and adjustment easier
- Analog Profile and Starfield Display compatible — analyzes heating and cooling efficiency with the M-Series Workstation

## Selection Charts

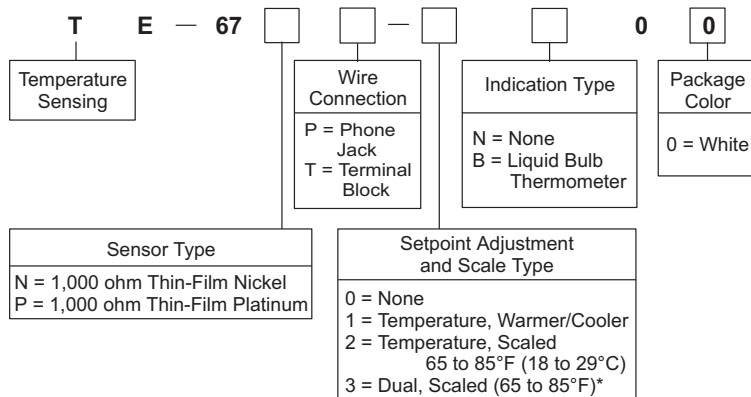

\* These models do not have a functioning LED, but all models have the manual override PB.

Example 1: To order a nickel sensor with a phone jack, a warmer/cooler temperature setpoint, and a liquid bulb thermometer, specify Product Code Number TE-67NP-1B00.

Example 2: To order a platinum sensor with a terminal block, a scaled temperature setpoint, and no indication, specify Product Code Number TE-67PT-2N00.

te-6700select.eps

## Accessories for TE-6700 Series

Code Number	Description
ACC-DWCLIP-0	Drywall Clip Mounting Kit (10 per bag)
ACC-INSL-0 1	Foam Pad Kit for Wallbox Mounting (10 per package)
ACC-INSL-1 1	Foam Pad Kit for Surface Mounting (10 per package)
GRD10A-608	Plastic Guard with Baseplate and Mounting Ring
T-4000-119	Allen-Head Adjustment Tool (30 per bag)
TE-67L-600	Fahrenheit Label Replacement Kit
TE-67L-601	Celsius Label Replacement Kit
TE-67MB-600	Mounting Base Kit
TE-67D0-601 2	Door Replacement Kit with a Johnson Controls Logo (10 per box)
TE-67D0-602 2	Door Replacement Kit without a Logo (10 per box)

1. These foam pads will prevent drafts from entering the unit through the wall, and make installation easier when mounting on an uneven surface.
2. Contains 10 original style and 10 new style doors

## Technical Specifications

TE-6700 2nd Generation Temperature Elements (Part 1 of 2)		
Nickel Sensor	Temperature Sensor	1,000 ohm thin-film nickel
	Temperature Coefficient	Approximately 3 ohms per F° (5.4 ohms per C°)
	Reference Resistance	1,000 ohms at 70°F (21°C)
	Accuracy:	±0.34F° at 70°F (±0.18C° at 21°C)
Platinum Sensor	Temperature Sensor	1,000 ohm thin-film platinum
	Temperature Coefficient	Approximately 2 ohms per F° (5.4 ohms per C°)
	Reference Resistance	1,000 ohms at 32°F (0°C)
	Accuracy	±0.65F° at 70°F (±0.36C° at 21°C)

The performance specifications are nominal and conform to acceptable industry standards. For applications at conditions beyond these specifications, consult the local Johnson Controls office. Johnson Controls, Inc. shall not be liable for damages resulting from misapplication or misuse of its products. © 2012 Johnson Controls, Inc. [www.johnsoncontrols.com](http://www.johnsoncontrols.com)

## TE-6700 2nd Generation Temperature Elements (Continued)

TE-6700 2nd Generation Temperature Elements (Part 2 of 2)		
Temperature Indicator	Type	Liquid filled bulb thermometer
	Range	40 to 90°F or 5 to 30°C
	Resolution	Fahrenheit scale graduated at 10F° intervals; Celsius scale and graduated at 5C° intervals.
Setpoint	Single Adjustment	Warmer/cooler, red/blue visual scale, or temperature – scaled °F/°C
	Dual Adjustment	Heating and cooling, graduated scale 65 to 85°F (Fahrenheit only: no Celsius scale)
	Resistance	Nominal 1.5k ohm
	Resolution	Fahrenheit scale graduated at 5F° intervals; Celsius scale at 2C° intervals
Sensor Response Time		One time constant = 8 minutes ±2 minutes at 10 feet per minute (fpm) airflow rate
Field Connections	Phone Jack	8-pin connector for 8-conductor 24 AWG phone cable
	Terminal Block	Screw type terminals for 18 to 24 AWG wire
Zone Bus Access		6-pin connector with front access for a laptop with HVAC PRO™ software, PalmPilot™ with VMA Balancing Tool (VBT) software, or a Zone Terminal (ZT).
Manual Override		Integral momentary pushbutton (DIP switch selectable)
LED Display	Red LED indicates three modes of operation (application and controller type dependent).	
Ambient Operating Conditions		32 to 131°F (0 to 55°C) 0 to 100% RH, noncondensing; 85°F (29°C) maximum dew point
Ambient Storage Conditions		-40 to 160°F (-40 to 71°C) 0 to 100% RH, noncondensing; 85°F (29°C) maximum dew point
Mounting Style		Standard base for both surface and U.S. wallbox mounting, including hardware
Materials		White PC/ABS plastic case and mounting base
Dimensions (H x W x D)		3.2 x 3.2 x 1.4 in. (81 x 81 x 36 mm)
Shipping Weight		1 lb (0.5 kg)

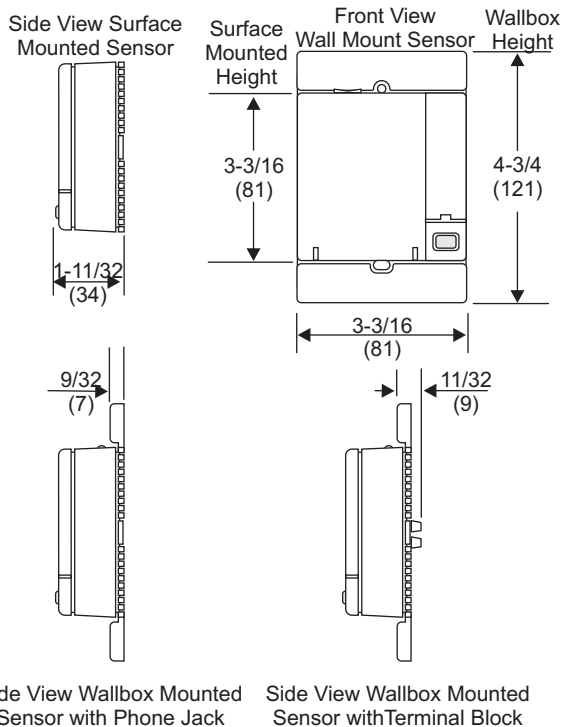

TE-6700 Temperature Element  
Dimensions, in (mm)

### Repair Information

If the TE-6700 Temperature Element fails to operate within its specifications, replace the unit. For a replacement element, contact the nearest Johnson Controls® representative.

te-6700dim.eps